

Fashion Bed Group

A Division of Leggett & Platt Incorporated
5950 West 51st Street - Chicago, IL 60638

Papillon Duo Parts List

CARTON

(11) PANEL

PART #362101 HARDWARE BAG FOR DUO ATTACHMENT TO FRAME

- (1) 1/4-20 X 2" FLAT ALLEN HEAD SCREW-4
- (2) 1/4-20 X 3/4" FLAT ALLEN HEAD SCREW-4
- (3) 1/4-20 X 1/2" FLAT ALLEN HEAD SCREW-4
- (4) 1/4-20 HEX NUT-4
- (5) 1/4" ID X 5/8" OD FLAT METAL WASHER-8
- (6) PLASTIC GLIDE -2 #150940000
- (7) FOOT METAL RING -2 #377001
- (8) ALLEN WRENCH
- (9) OPEN WRENCH
- (10) LEG EXTENSION-2 #377002

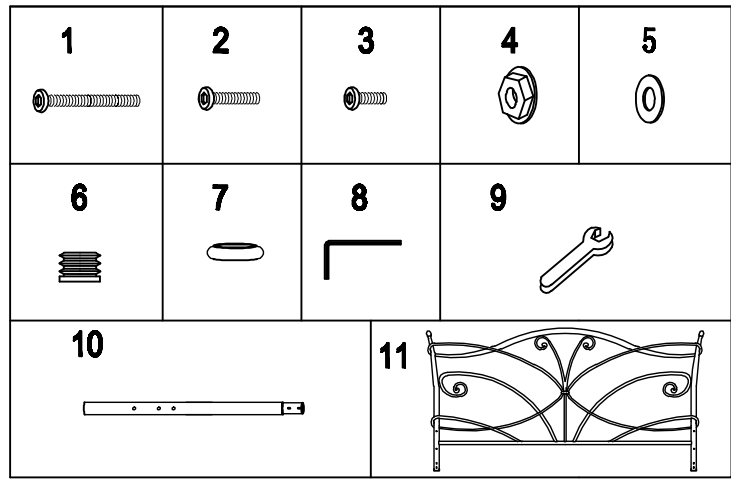

PRODUCT FULLY ASSEMBLED

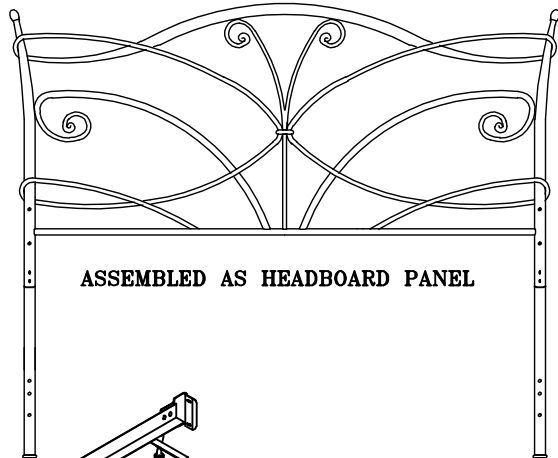

ASSEMBLED AS HEADBOARD PANEL

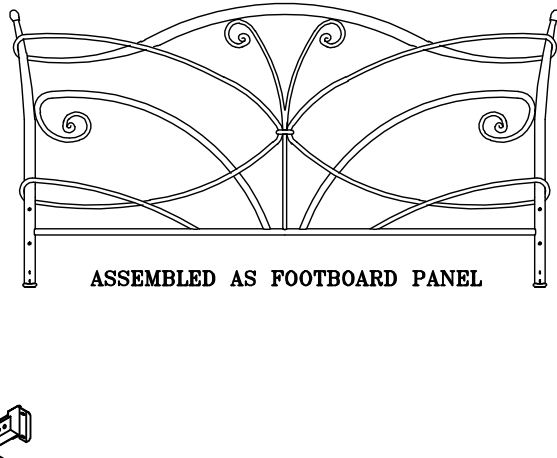

ASSEMBLED AS FOOTBOARD PANEL

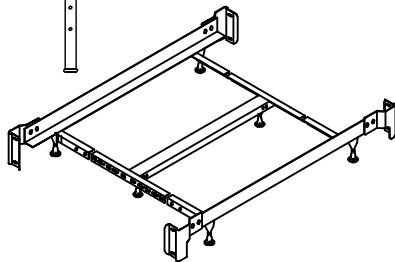

QUEEN - KING BED FRAME FULLY ASSEMBLED
NOTE: SEE INSTRUCTIONS INCLUDED IN FRAME CARTON FOR FRAME ASSEMBLY

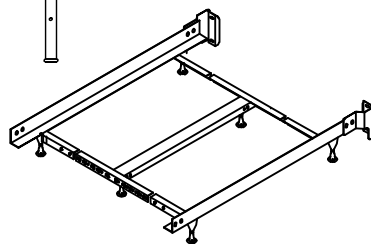

QUEEN - KING HEADBOARD ONLY FRAME FULLY ASSEMBLED
NOTE: SEE INSTRUCTIONS INCLUDED IN FRAME CARTON FOR FRAME ASSEMBLY

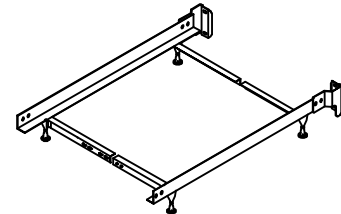

TWIN - FULL HEADBOARD ONLY FRAME FULLY ASSEMBLED
NOTE: SEE INSTRUCTIONS INCLUDED IN FRAME CARTON

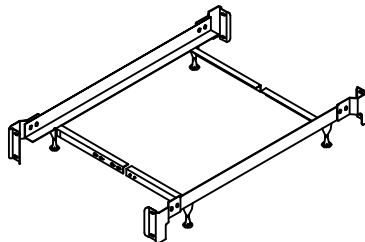

TWIN - FULL BED FRAME FULLY ASSEMBLED
NOTE: SEE INSTRUCTIONS INCLUDED IN FRAME CARTON FOR FRAME ASSEMBLY

FOR ASSISTANCE IN ASSEMBLY ONLY OF THIS PRODUCT. CALL OUR HELP DESK AT 1-800-324-3415, BETWEEN 8:30 AM & 4:30 PM CENTRAL TIME MONDAY THRU FRIDAY. PLEASE HAVE THE STYLE NUMBER AVAILABLE BEFORE YOU CALL. (STYLE # OR NAME CAN BE FOUND ON PACKING CARTON OR SALES RECEIPT.) OUR PRODUCT IS INSPECTED TO ENSURE IT IS IN GOOD CONDITION. IF YOUR FURNITURE APPEARS TO HAVE BEEN DAMAGED IN SHIPMENT OR YOU ARE IN NEED OF REPLACEMENT PARTS PLEASE CONTACT THE DEALER FROM WHOM YOU PURCHASED THE PRODUCT.

TOC20111220

Instruction Sheet

SAVE ALL PACKAGING MATERIALS UNTIL PRODUCT IS FULLY ASSEMBLED. HARDWARE AND SMALL PIECES MAY NOT BE SEEN AND COULD BE ACCIDENTALLY DISCARDED WITH PACKAGING MATERIALS.

FIGURE 1

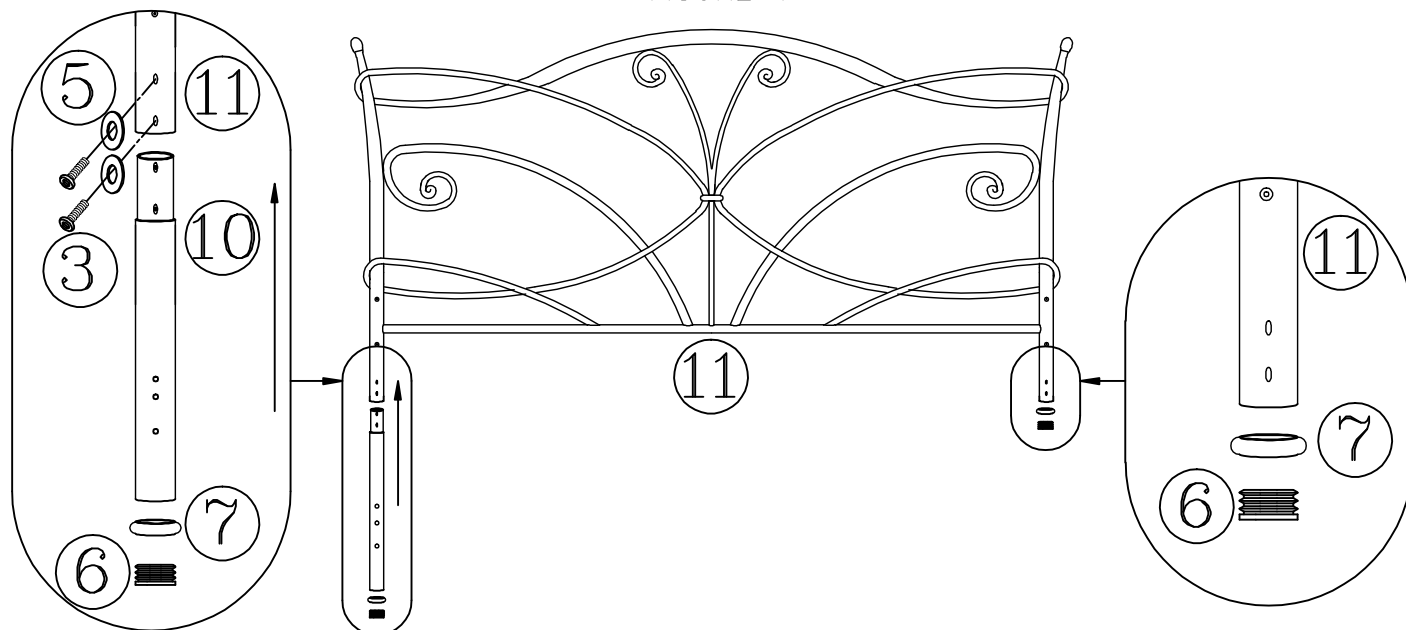
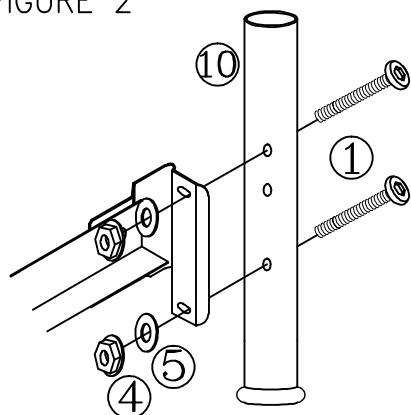

FIGURE 2



NOTE: This product can be used as Headboard only or as Headboard/Footboard bed. Insert foot metal ring (7) into leg extension (10) secure foot metal ring (7) with plastic glide (6) for headboard assembly. (See Figure 1)
For footboard assembly insert foot metal ring (7) into bottom of panel (11) post secure foot metal ring (7) with plastic glide (6). (See Figure 1)

Step 1 Assembly Headboard Panel

- Align top reduction of leg extension (10) with bottom of panel (11) post.
- Now carefully insert leg extension (10) into bottom of panel (11) post. (See Figure 1)
- Secure leg extension (10) with screws (3) and flat metal washer (5).
- Tighten screws (3) with Allen wrench (8).
- Repeat on other side of panel (11). (See Figure 1)

Step 2 Headboard Frame Assembly

- Place headboard and frame in desired location in room.
- Place 2 screws (1) through holes located in leg extension (10). (See Figure 2)
- Align bed frame bracket over screws.
- Place a flat washer (5) first and then a hex nut (4) on each screw. DO NOT TIGHTEN SCREWS COMPLETELY.
- Repeat on other side of headboard panel.
- Tighten all screws securely using the Allen wrench (8) and open wrench (9).

FIGURE 3

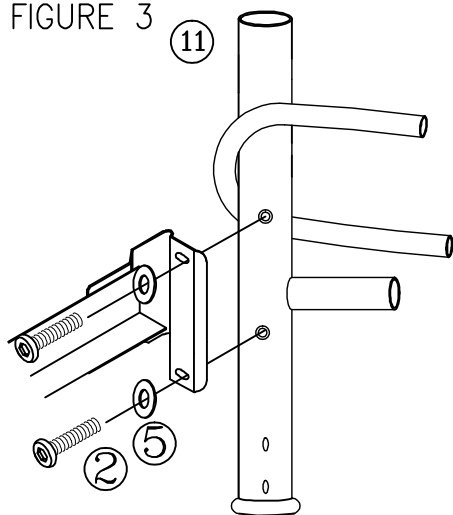

Step 3 Footboard Frame Assembly

- Discard Leg extension (10) for footboard attachment to frame.
- Position panel (11) and align holes in the post with holes in the frame bracket. (See Figure 3)
- Place washer (5) over on each screw (2). Insert through frame bracket and into panel (11) post. DO NOT TIGHTEN SCREWS COMPLETELY.
- Repeat on other side of footboard panel.
- Tighten all screws securely using the Allen wrench (8).