



Q.A. FILE CABINET

# PARTS LIST



A: TOP 1PC



B: LEFT SIDE PANEL 1PC



C: RIGHT SIDE PANEL 1PC



D: BACK RAIL 1PC

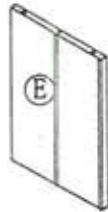

E: FRONT PANEL 1PC



F: BACK PANEL 1PC



G: LEG 4PCS

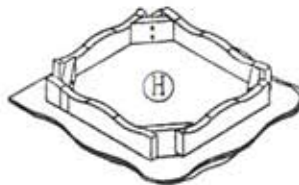

H: BOTTOM 1PC

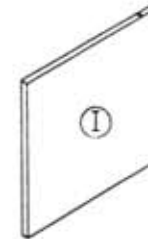

I: CENTER RIGHT PANEL 1PC



J: DRAWER LEFT PANEL 1PC

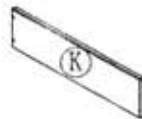

K: DRAWER RIGHT PANEL 1PC

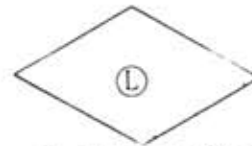

L: DRAWER BOTTOM 1PC



M: DRAWER BACK 1PC



N: DRAWER FRONT 1PC

# PARTS LIST

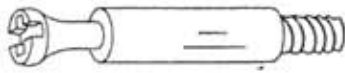

a: CAM-BOLT  
10PCS



b: CAM-LOCK  
10PCS



c: CAM-COVER  
10PCS



d: HANDLE  
4PCS

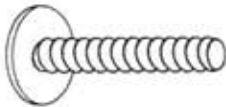

e: SHORT MACHINE SCREW  
8PCS

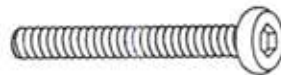

f: LARGE MACHINE SCREW  
8PCS



g: WASHER  
8PCS

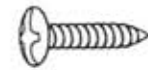

h: ROUND WOOD  
SCREW 14PCS



i: WOOD DOWEL 10PCS



j: LID SUPPORT 1PC



k: SHORT ALUMINUM BAR  
2PCS 14 1/4"



l: LONG ALUMINUM BAR  
2PCS 14 7/8"



m: FLAT WOOD SCREW  
2PCS

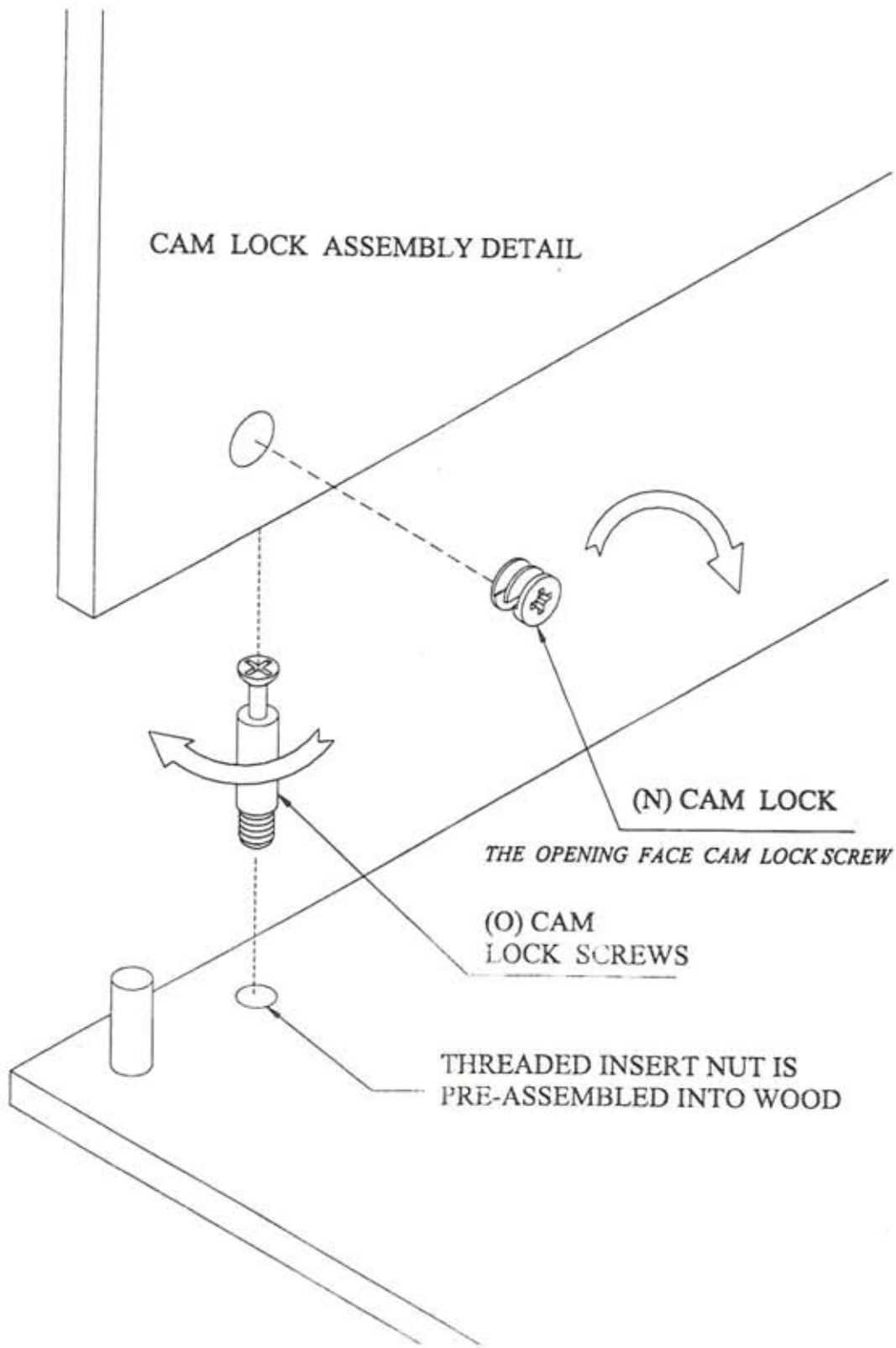

# ASSEMBLY INSTRUCTIONS

THANK YOU FOR PURCHASING THIS QUALITY PRODUCT. PLEASE CHECK ALL PACKING MATERIAL FOR PARTS WHICH MAY HAVE COME LOOSE INSIDE THE CARTON DURING SHIPMENT. COUNT ALL PARTS AND HARDWARE, COMPARE WITH PARTS LIST TO BE SURE ALL PARTS ARE PRESENT.

STEP 1 –

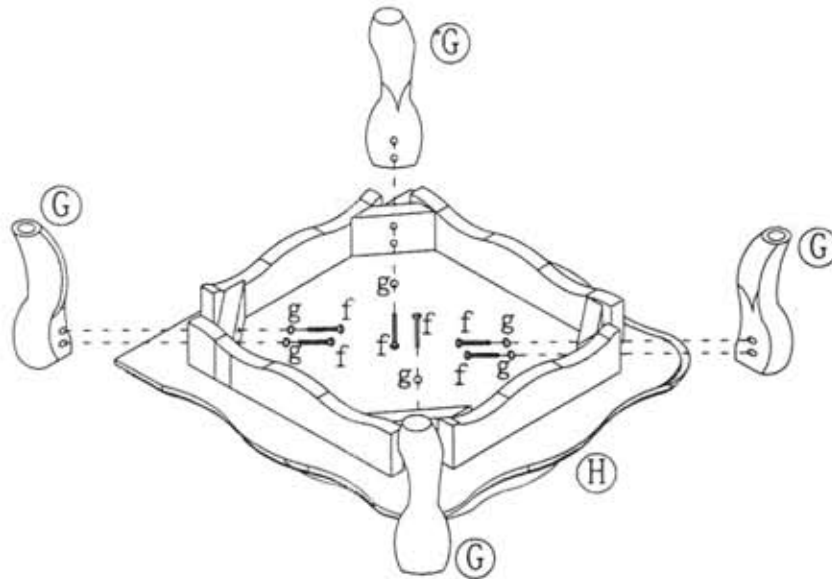

1. TURN BOTTOM (H) UPSIDE DOWN ON A SOFT WORKIN SURFACE.
2. ATTACH LEGS (G) TO BOTTOM (H) WITH WASHERS (g) AND LARGE MACHINE SCREWS (f) AND TIGHTEN.
3. TURN THE ASSEMBLY RIGHT SIDE UP..

STEP 2 –

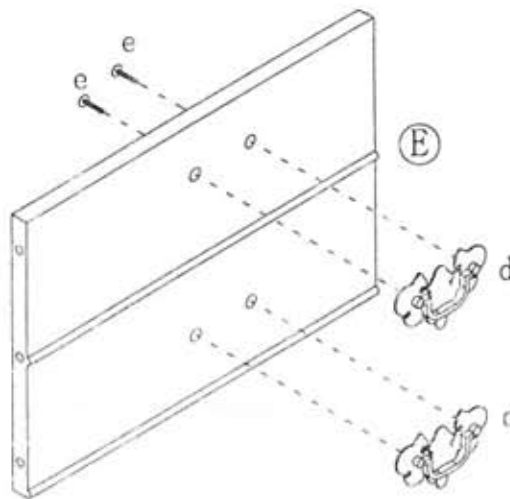

4. ATTACH HANDLES (d) TO FRONT PANEL (E) WITH SHORT MACHINE SCREWS (e) AND TIGHTEN.

STEP3-

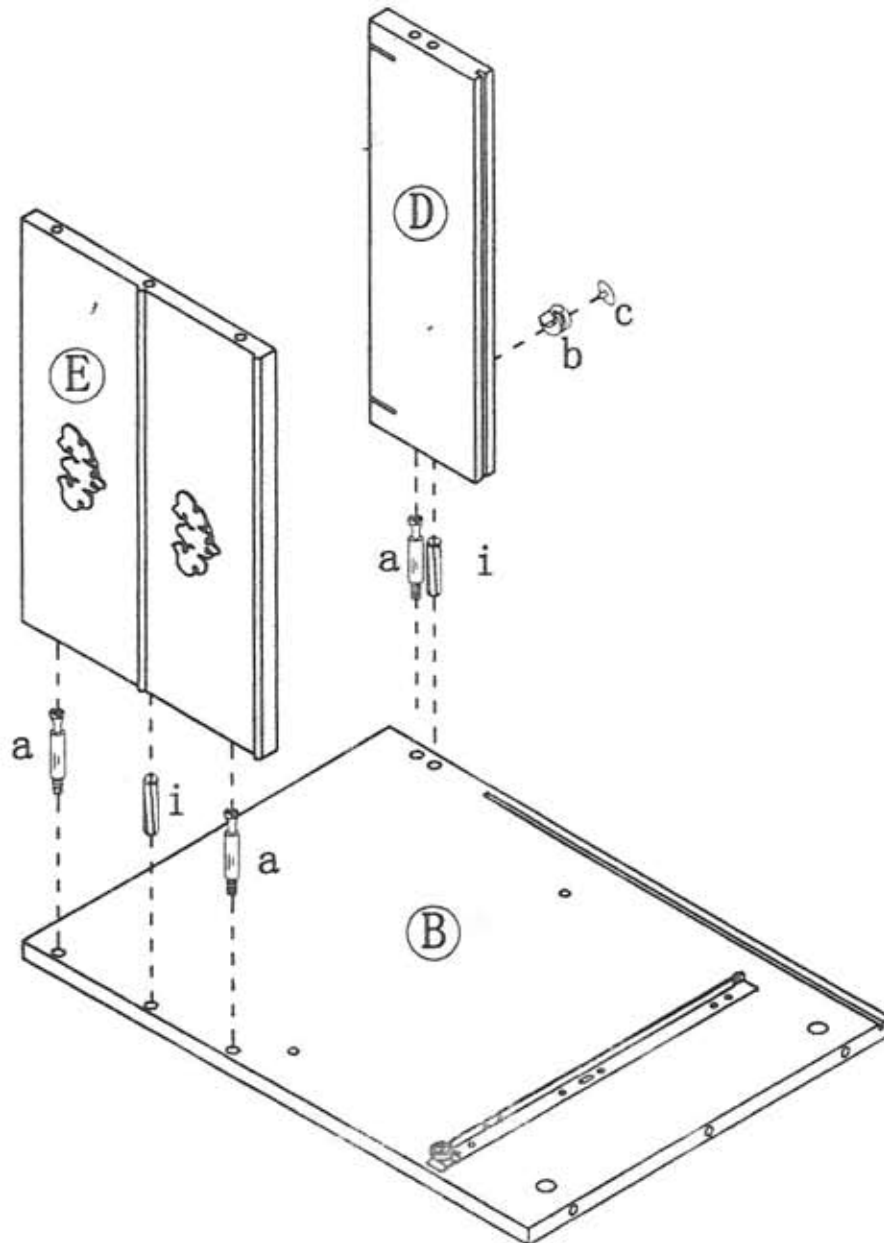

5. SCREW CAM-BOLTS (a) INTO THREADED INSERTS IN SIDE PANEL (B & C). INSERT WOOD DOWELS (i) INTO PREDRILLED HOLES IN SIDE PANELS (B & C).

6. ATTACH FRONT PANEL (E) AND BACK RAIL (D) TO LEFT SIDE PANEL (B) BY INSERTING CAM LOCKS (b) INTO PREDRILLED HOLES IN FRONT PANEL (E) AND BACK RAIL (D) AND TIGHTEN CLOCKWISE. (SEE CAM LOCK ASSEMBLY DETAILS)

7. COVER CAM LOCK HOLES WITH PLASTIC COVER (c).

STEP 4 –

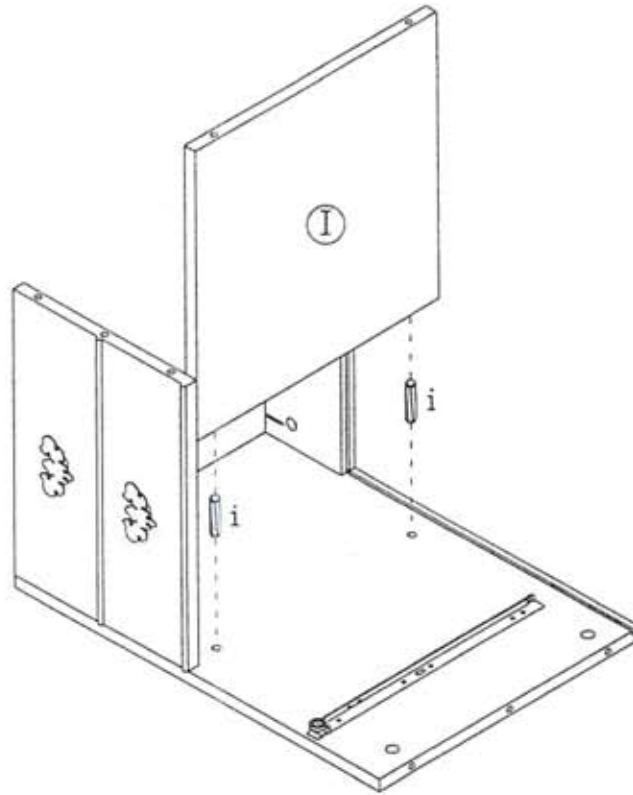

8. ATTACH CENTER SHELF (I) TO LEFT SIDE PANEL (B) WITH WOOD DOWELS (i).

STEP 5 –

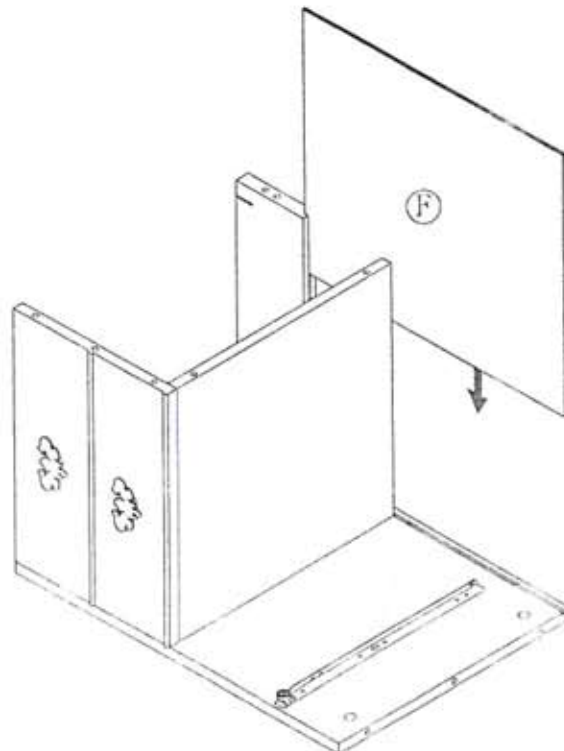

9. INSERT BACK PANEL (F) INTO GROOVES IN BACK RAIL (D) AND LEFT SIDE PANEL (B).

STEP 6 –

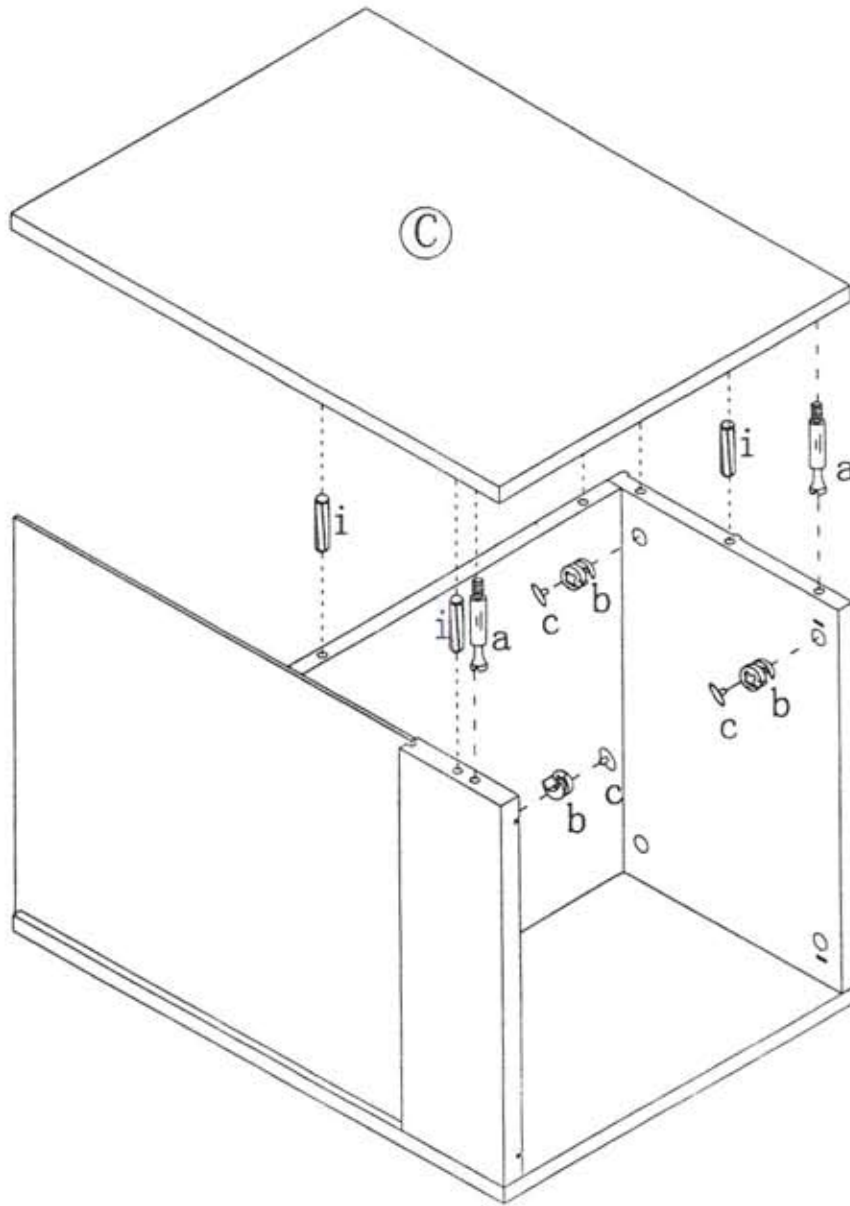

10. REPEAT POINT (6), (7), (8), (9), TO ATTACH FRONT PANEL (E), BACK RAIL (D), CENTER SHELF (I) AND BACK PANEL (F) TO RIGHT SIDE PANEL (C).

STEP 7 –

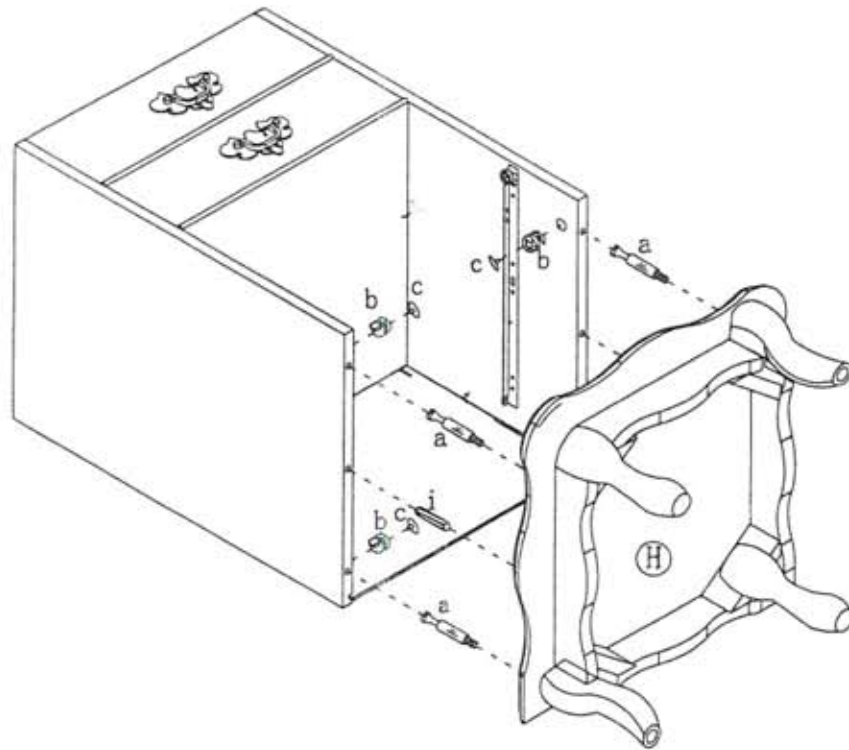

11. SCREW CAM-BOLTS (a) INTO THREADED INSERTS IN BOTTOM (H).  
INSERT WOOD DOWELS (i) INTO PREDRILLED HOLES IN BOTTOM (H).
12. ATTACH THE ASSEMBLY (B, C, D, E, F & I) TO BOTTOM (H) BY  
INSERTING CAM LOCKS (b) INTO PREDRILLED HOLES IN SIDE PANELS (B  
& C) AND TIGHTEN CLOCKWISE. COVER CAM LOCK HOLES WITH  
PLASTIC COVER (c).

STEP 8 –

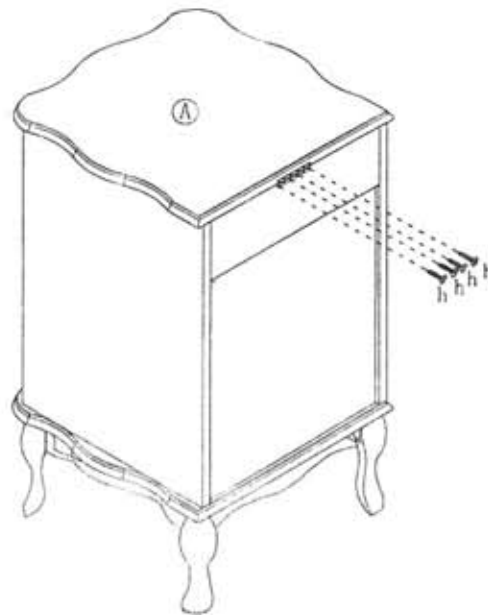

13. ATTACH TOP (A) TO BACK RAIL (D) WITH ROUND WOOD SCREWS (h).  
STEP 9 –

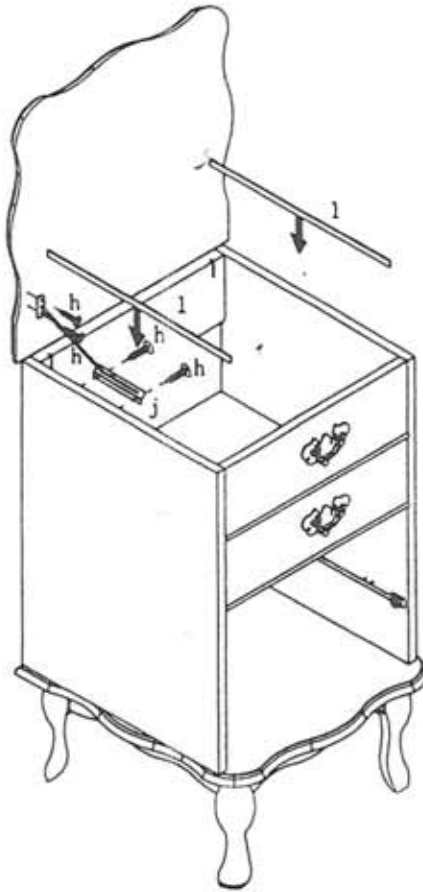

14. ATTACH LID SUPPORT (j) TO TOP (A) AND LEFT SIDE PANEL (B) WITH  
ROUND WOOD SCREWS (h).

15. INSERT LARGE ALUMINUM BAR (l) INTO SLOTS IN BACK RAIL (D)  
AND FRONT PANEL (E).

STEP 10 –

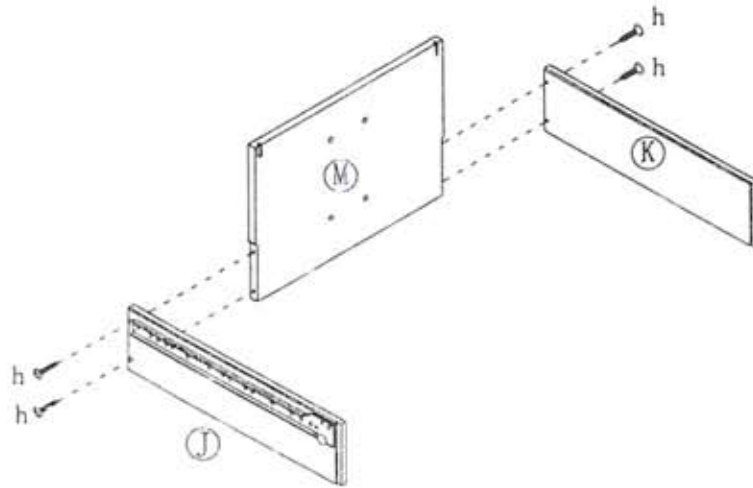

19. INSERT DRAWER BOTTOM (L) INTO GROOVES IN DRAWER SIDES (J & K) AND DRAWER FRONT (N).

STEP 13 –

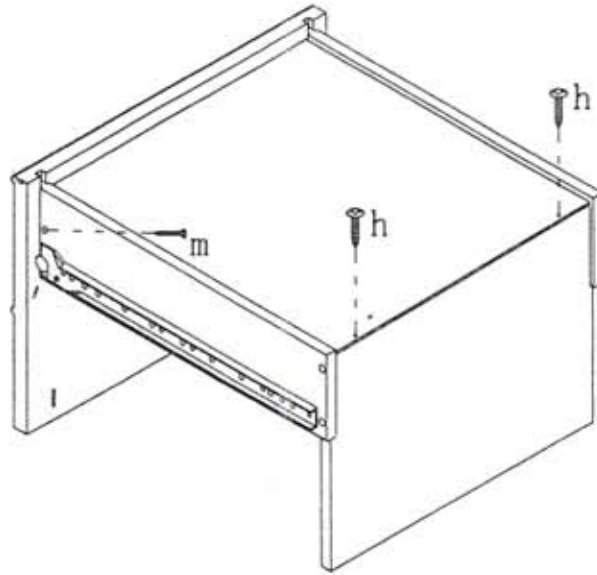

20. SECURE DRAWER BOTTOM (L) TO DRAWER BACK (M) WITH ROUND WOOD SCREWS (h).

21. SECURE DRAWER SIDES (J & K) TO DRAWER FRONT (N) WITH FLAT WOOD SCREWS (m).

STEP 14 –

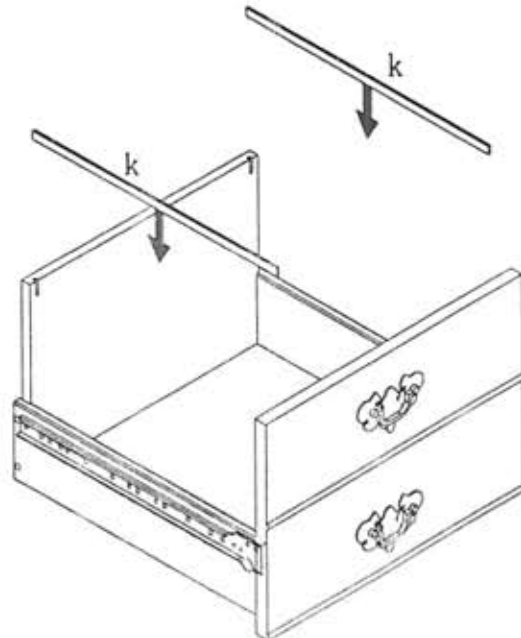

22. INSERT SMALL ALUMINUM BARS (k) INTO SLOTS IN DRAWER BACK (M) AND DRAWER FRONT (N).

STEP 15 –



23. INSERT DRAWER ASSEMBLY INTO FILE CABINET.