

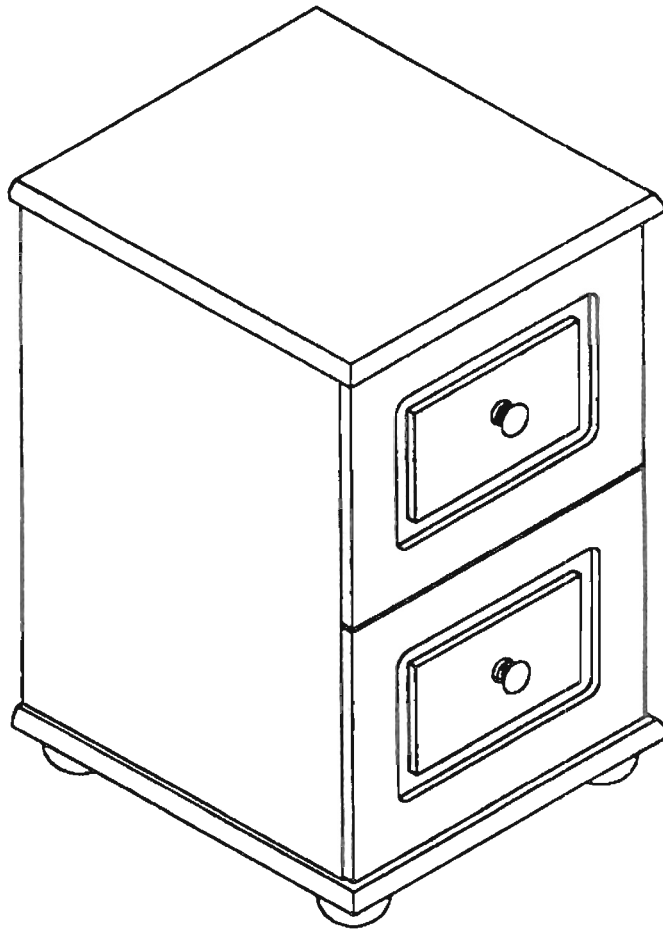

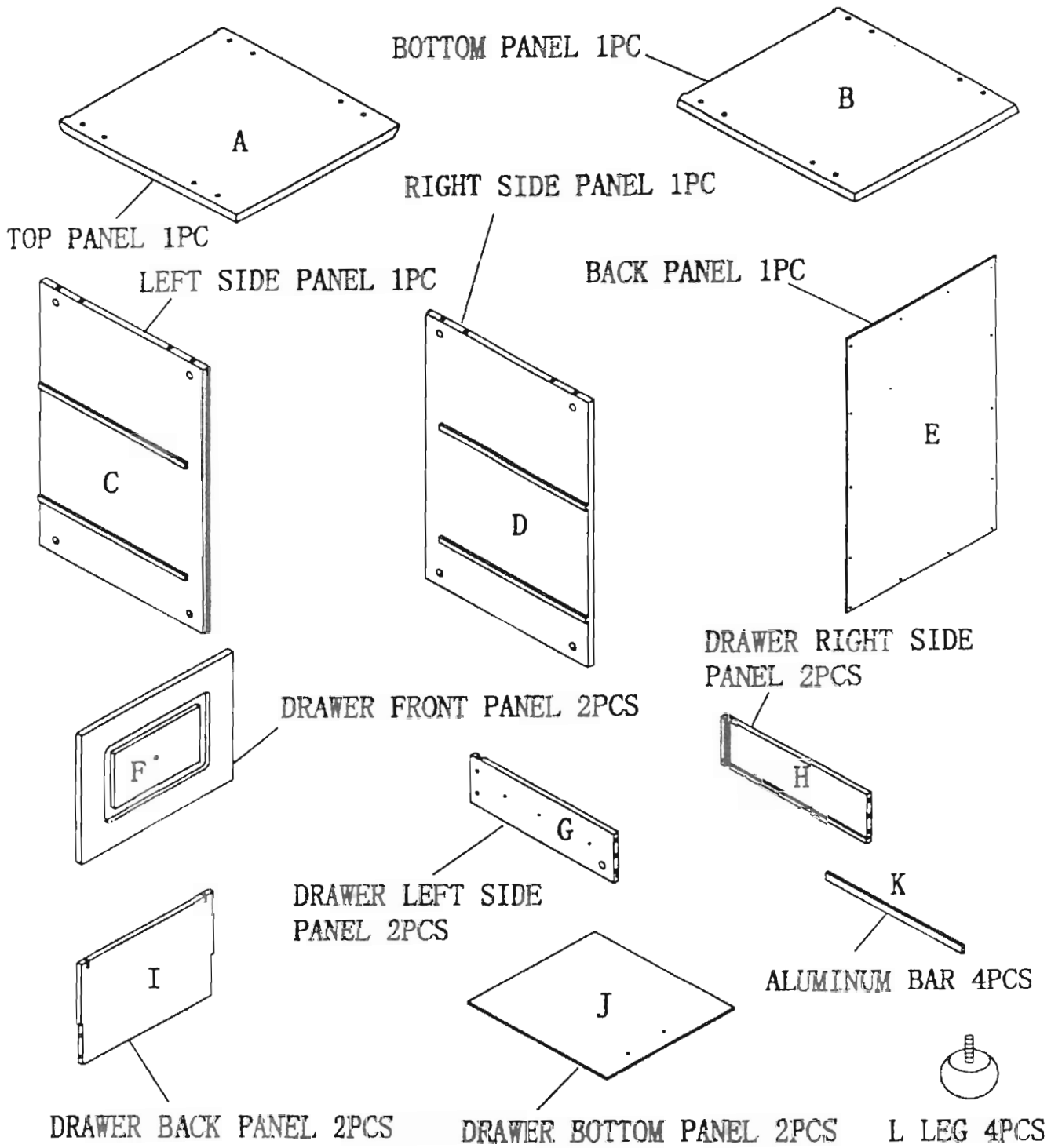







# Assembly Instructions

#1428W AMELIA FILE CABINET  
#2715 2 DRAWER FILE CABINET  
#3715 2 DRAWER FILE CABINET  
#4715 2 DRAWER FILE CABINET  
#5715 2 DRAWER FILE CABINET





- |   |   |  |   |
|---|---|--|---|
|  M CAM LOCK<br>12PCS           |  N CAM LOCK SCREW<br>12PCS   |  O WOOD DOWEL<br>16PCS      |  P KNOB 2PCS               |
|  Q PHILLIPS HEAD<br>SCREW 2PCS |  R ROUND HEAD<br>SCREW 14PCS |  S FLAT HEAD<br>SCREW 16PCS |  T 3/4" WOOD<br>SCREW 8PCS |
|  U "L" WRENCH 1PC              |  V GLUE 1PC                  |  |   |

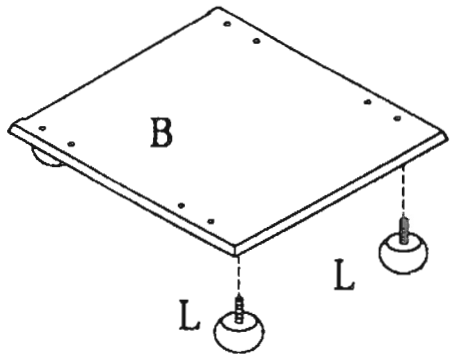

STEP 1

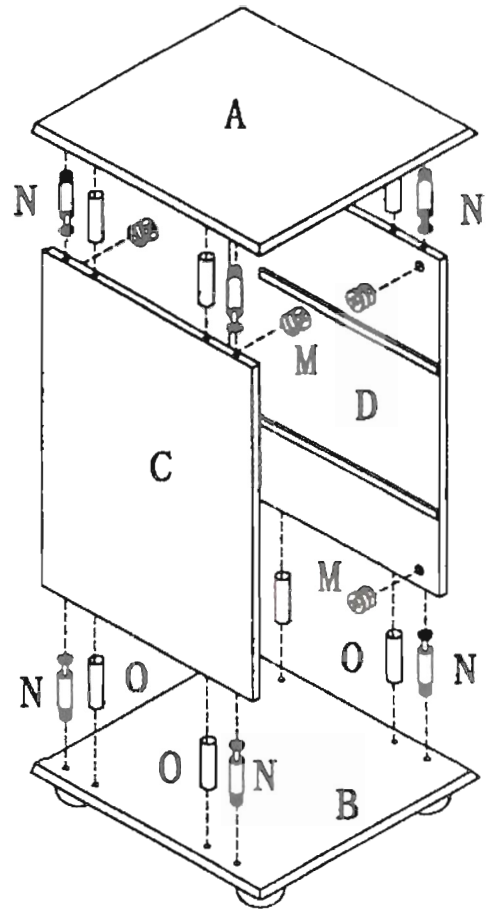

STEP 2

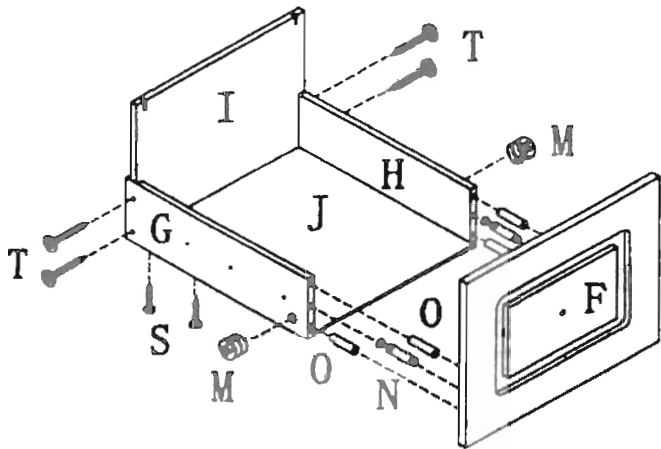

STEP 3

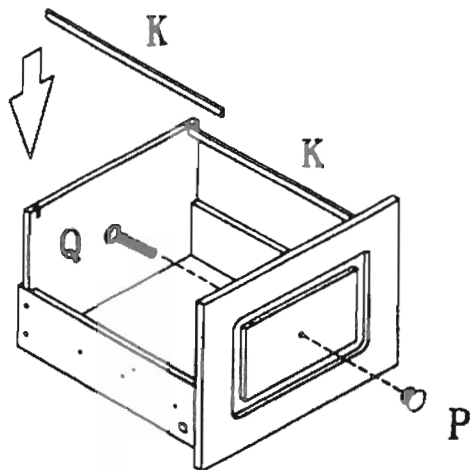

STEP 4

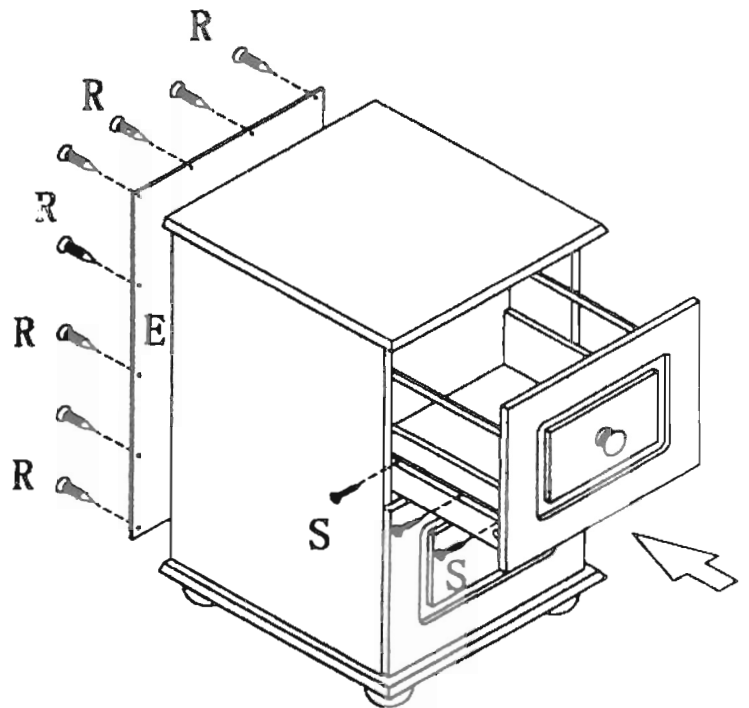

STEP 5

**CAM LOCK ASSEMBLY DETAIL**

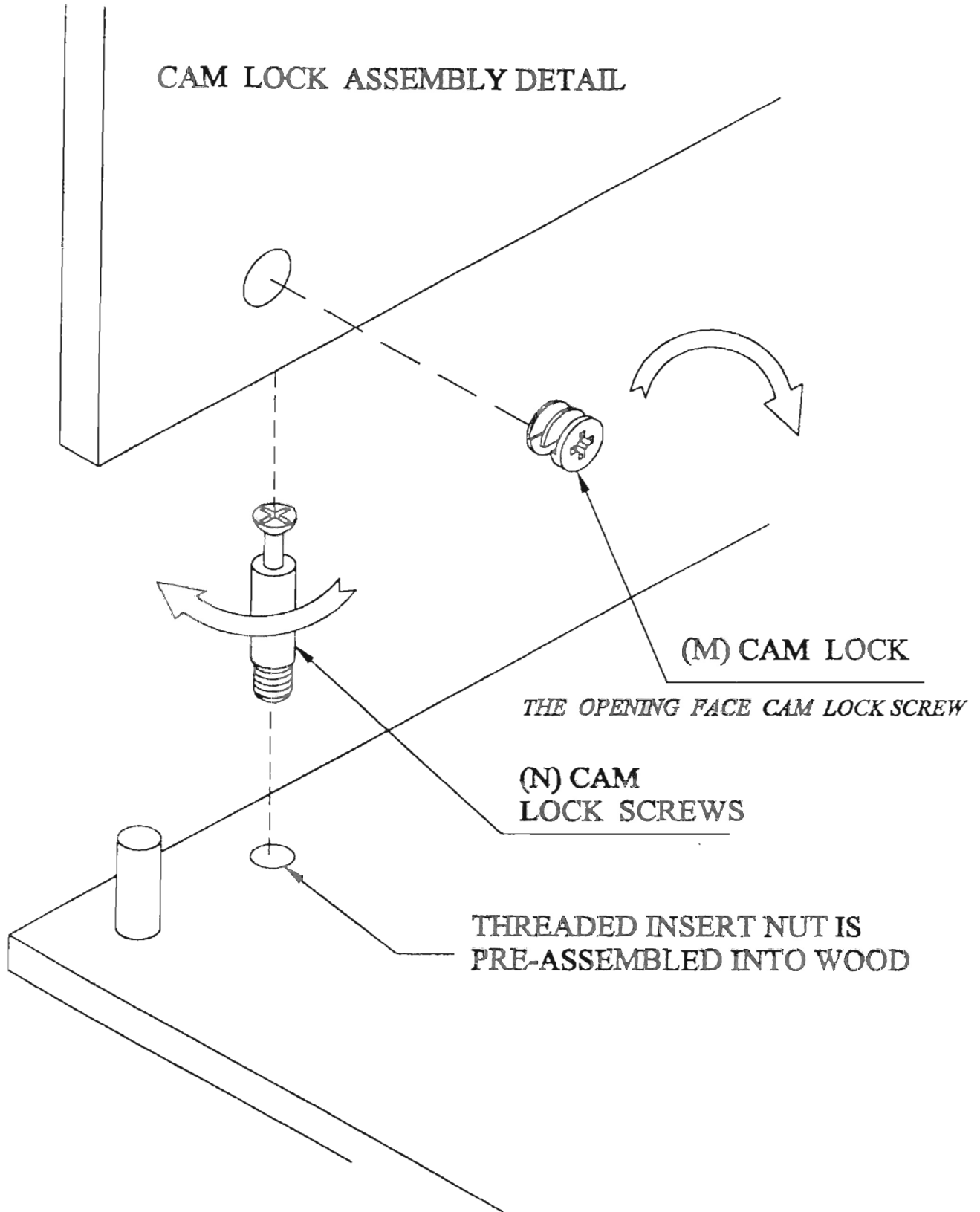

FILE CABINET  
ITEM # 1428W  
# 2715  
# 3715  
# 4715  
# 5715

PARTS LIST

<u>LETTER KEY</u>	<u>DESC.</u>	<u>Q'TY</u>
A	TOP	1
B	BOTTOM	1
C	LEFT SIDE PANEL	1
D	RIGHT SIDE PANLE	1
E	BACK	1
F	DRAWER FRONT	2
G	DRAWER LEFT SIDE PANEL	2
H	DRAWER RIGHT SIDE PANEL	2
I	DRAWER BACK PANEL	2
J	DRAWER BOTTOM PANEL	2
K	ALUMINUM BAR	4
L	FOOT	4
M	CAM LOCK	12
N	CAM LOCK SCREW	12
O	WOOD DOWEL	16
P	DRAWER KNOB	2
Q	PHILLIPS HEAD SCREW	2
R	ROUND WOOD SCKEW	14
S	FLAT WOOD SCREW	16
T	LARGE WOOD SCREW	8
U	ALLEN WRENCH	1
V	GLUE	1

## ASSEMBLY INSTRUCTIONS

- 1) ATTACH FEET (L) TO BOTTOM (B) AND TIGHTEN.
- 2) INSERT WOOD DOWELS (O) INTO PREDRILLED HOLES IN TOP (A) AND BOTTOM (B) WITH PROPER AMOUNT OF GLUE (V) APPLIED.
- 3) SCREW CAM LOCKS (N) ONTO INSERTED THREADS IN TOP(A) AND BOTTOM(B).
- 4) ATTACH SIDE PANELS (C&D) TO BOTTOM (B) BY INSERTING CAM LOCKS (M) INTO PREDRILLED HOLES IN SIDE PANELS (C&D) AND TIGHTEN CLOCKWISE. (SEE CAM LOCK ASSEMBLY DETAILS)
- 5) REPEAT STEP (4) TO ATTACH SIDE PANELS(C&D) TO TOP (A).
- 6) ATTACH DRAWER SIDE PANALS (G&H) TO BACK PANEL (I) WITH LARGE WOOD SCREWS (T).
- 7) INSERT DRAWER BOTTOM PANEL (J) INTO GROOVES IN DRAWER SIDE PANELS (G&H) AND DRAWER BACK PANEL (I).
- 8) INSERT WOOD DOWELS (O) INTO PREDRILLED HOLES IN DRAWER SIDE PANELS (G&H) WITH PROPER AMOUNT OF GLUE (V) APPLIED.
- 9) SCREW CAM LOCK SCREWS (N) ONTO INSERTED THREADS IN DRAWER FRONT (F).

- 10) ATTACH DRAWER FRONT (F) TO DRAWER SIDE PANELS (G&H) BY INSERTING CAM LOCKS (M) INTO PREDRILLED HOLES IN DRAWER SIDE PANELS (G&H) AND TIGHTEN CLOCKWISE.
- 11) ATTACH DRAWER KNOBS (P) TO DRAWER FRONT (F) WITH PHILLIPS HEAD SCREWS (Q).
- 12) PLACE ALUMINUM BARS (K) TO DRAWER FRONT (F) AND BACK (I).
- 13) ATTACH BACK PANEL (E) TO TOP (A), BOTTOM (B) AND SIDES (C&D).
- 14) INSERT DRAWER ASSEMBLY INTO CABINET.

CUSTOMER MAY NOT HAVE THIS FINAL STEP IN THE ASSEMBLY

- 15) Pull the inner section of each drawer glide out from the side panels (C & D). There should be 3 small markings on the outside of the drawer sides (G & H). It will probably take two people to do this part. Line up the markings on the drawer side with the holes in the glide. Insert screw through the hole in the glide and line it up with the marking on the drawer side. Attach drawer to glide on both sides (3 screws on each side). When attached, the drawer should glide easily into the recess of the cabinet. Do this for both drawers and the assembly should be complete.