









Chintaly Imports.

## GENERAL INFORMATION

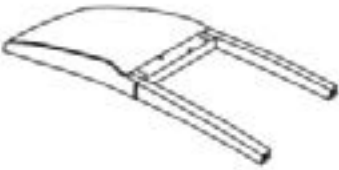
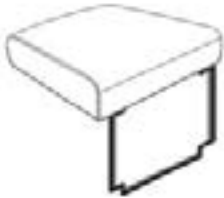
PLEASE READ THESE ASSEMBLY INSTRUCTION PRIOR TO ASSEMBLING.

TO AVOID DAMAGE, ASSEMBLE THE CHAIR ON A NON-ABRASIVE SURFACE, EG, A CARPET  
MAKE SURE ALL BOLTS ARE TIGHTLY FASTENED BEFORE THE CHAIR IS USED.

### \* PART AND HARDWARE LIST

<b>A</b> 		<b>B</b> 		<b>C</b> 	
Chair Back	1PC	Seat	1PC	Front Leg	2PCS
<b>1</b>  8mm in Dia. X 85mm in L.		<b>2</b>  8mm in Dia. X 60mm in L.		<b>3</b> 	
Long Bolt	4PCS	Short Bolt	6PCS	Spring Washer	10PCS
<b>4</b> 		<b>5</b> 			
Flat Washer	10PCS	Allen Key	1PC		

# Assembly Instructions

ITEM NO: MARIA-PRS-SC DINING CHAIR

Do not fasten any screws until the chair is fully assembled.

## STEP 1

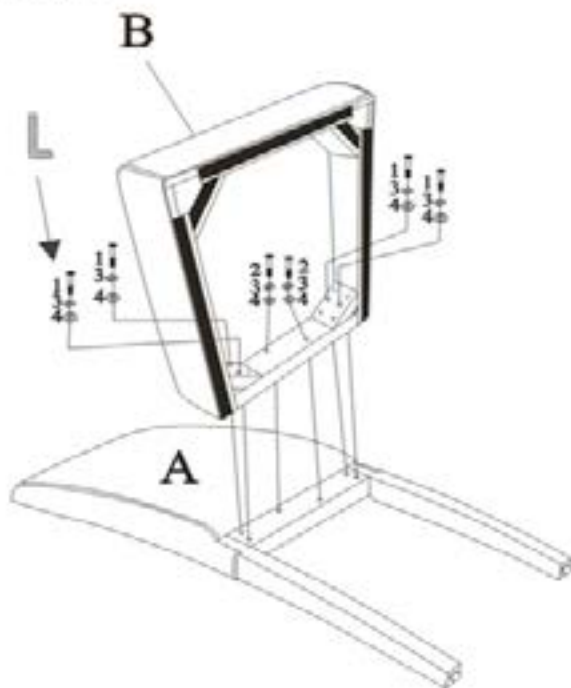

Attach the Seat (B) to the Chair Back (A) using four Long Bolts (1), two Short Bolts (2), six Spring Washers (3) and six Flat Washers (4), and with the provided Allen Key (5).

## STEP 2

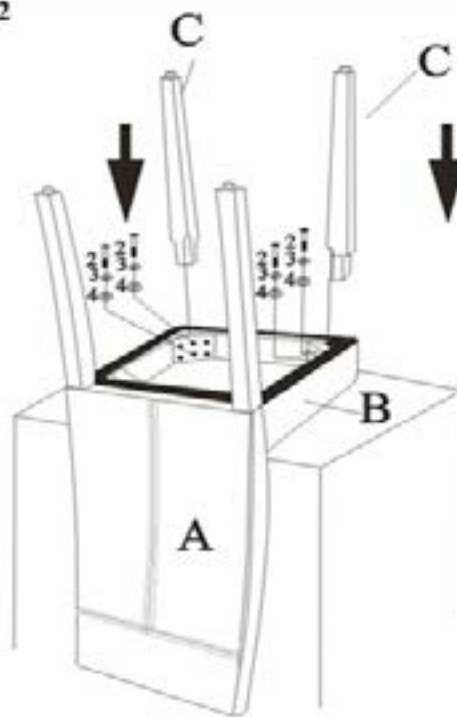

Place the Seat (B) upside down on a non-abrasive table surface. Assemble the Front Legs (C) to the front of the Seat (B) using four Bolts (2), four Spring Washers (3) and four Flat Washers (4), with the provided Allen Key (5).

## STEP 3

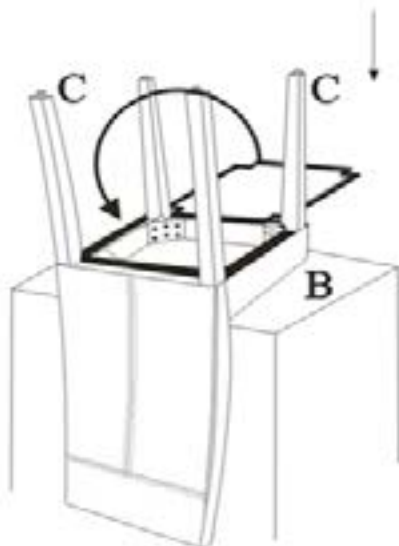

Place the Vinyl Flap to the bottom of the Seat (B), using the adhesive strip as shown.

## STEP 4



Finally, ensure the Chair is level on the floor and then fully tighten all the Bolts. Now the chair is completely assembled.