







Examine all packaging material for small parts that may have come loose during shipment. Periodic checks are recommended to insure that all components are in proper position, tight and free from damage. Keep this assembly instruction for future reference. Adult assembly is required. The product of Hillsdale Furniture, LLC is designed for residential use only. Customer Service Phone Number: 502-562-0000

**HARDWARE LIST**

- A (4) 1/4" x 3" Allen Bolts
- B (4) 1/4" x 2-1/4" Allen Bolts
- C (1) 1/4" x 1-1/2" Allen Bolt
- D (9) 1/4" Spring Washers
- E (9) 1/4" x 19mm Flat Washers
- F (1) 4mm Allen Wrench

**PARTS LIST**

- G (1) Chair Back
- H (1) Seat Base
- I (2) Front Legs

PART	QTY	HARDWARE	PART	QTY	HARDWARE
A	4		B	4	
C	1		D	9	
E	9		F	1	

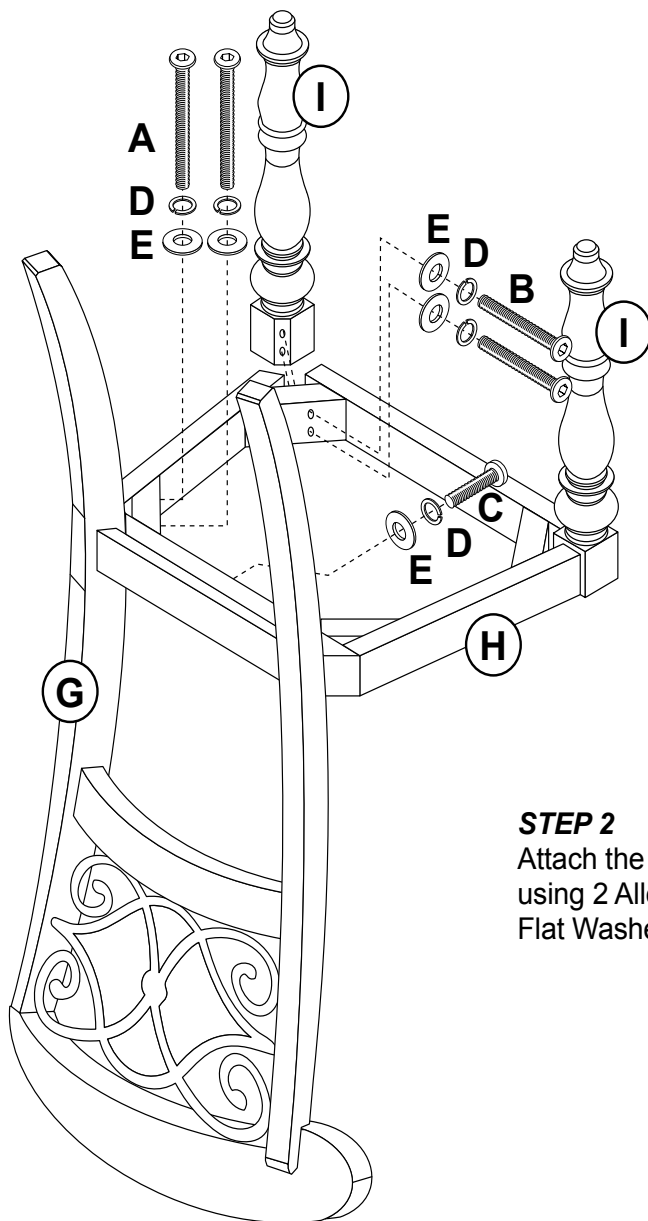
**STEP 1**

Begin assembly by attaching the Seat Base (H) to the Chair Back (G) by using 1 Allen Bolt C, 1 Spring Washer (D) and 1 Flat Washer (E) from the middle and then 2 Allen Bolts (A), 2 Spring Washers (D) and 2 Flat Washers (E) from the sides.

**STEP 2**

Attach the 2 Front Legs (I) to the Seat Base (H) by using 2 Allen Bolts (B), 2 Spring Washers (D) and 2 Flat Washers (E) per side.

TOC20120620

**CARE & MAINTENANCE:** The touch of a soft cloth is all the maintenance the finish will ever need. Please do not use harsh or abrasive cleaners for polishing, as they may cause damage to the finish. Periodic checks are recommended to make sure that all bolts, screws and nuts are securely tightened.

## BERGAMO SWIVEL STOOLS

Model #4299-826 Swivel Counter Stool

Model #4299-830 Swivel Bar Stool

Examine all packaging material for small parts that may have come loose during shipment. Periodic checks are recommended to insure that all components are in proper position, tight and free from damage. Keep this assembly instruction for future reference. Adult assembly is required. Customer Service Phone Number: 502-562-0000

### HARDWARE LIST

- A (8) Allen Bolts 1/4" x 1 1/4"
- B (4) Allen Bolts 1/4" x 2 1/4"
- C (6) Allen Bolts 1/4" x 3/4"
- D (4) Allen Bolts 5/16" x 1 3/4"
- E (4) Spring Washers 5/16"
- F (4) Flat Washers 5/16" x 19mm
- G (4) Flat Washers 5/16" x 16mm
- H (18) Spring Washers 1/4"
- I (4) Flat Washers 1/4" x 13mm
- J (14) Flat Washers 1/4" x 19mm
- K (3) Flat Metal Plates 1/4"
- L (1) Allen Wrench 4mm
- M (1) Allen Wrench 5mm

### PARTS LIST

- N (1) Stool Back
- P (1) Seat Base
- R (1) Stool Base
- S (4) Legs
- T (1) Support Ring

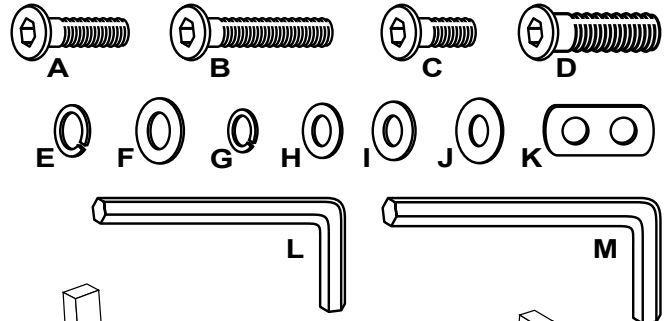

### STEP 1

Begin the assembly by attaching the Seat Base (P) to the Stool Back (N) by aligning holes and securing with 4 Allen Bolts (D), 4 Spring Washers (E) & 4 Flat Washers (F) from the inside to hold in place. Do not fully tighten bolts for this step.

### STEP 2

Once in place, secure the Flat Metal Plates (K) into the open areas with 2 Allen Bolts (C), 2 Spring Washers (G) & 2 Flat Washers (J) per each plate. Tighten all bolts using the Allen Wrenches (L & M) that have been provided.

### STEP 3

Attach each Leg (S) to the Stool Base (R) by inserting each in place and securing with 2 Allen Bolts (D), 2 Spring Washers (E) & 2 Flat Washers (G) per each leg. During assembly, attach the Support Ring (T) to each Leg by aligning holes and using 1 Allen Bolt (A), 1 Spring Washer (G) & 1 Flat Washer (H) per each Leg to secure in place. Tighten all bolts only after the Support Ring is in the proper location.

### STEP 4

Attach the assembled Stool sections by aligning the holes on the swivel metal plate with those on the Stool Base (R) and secure with 4 Allen Bolts (B), 4 Spring Washers (G) & 4 Flat Washers (J). The assembly of your new stool is now complete.

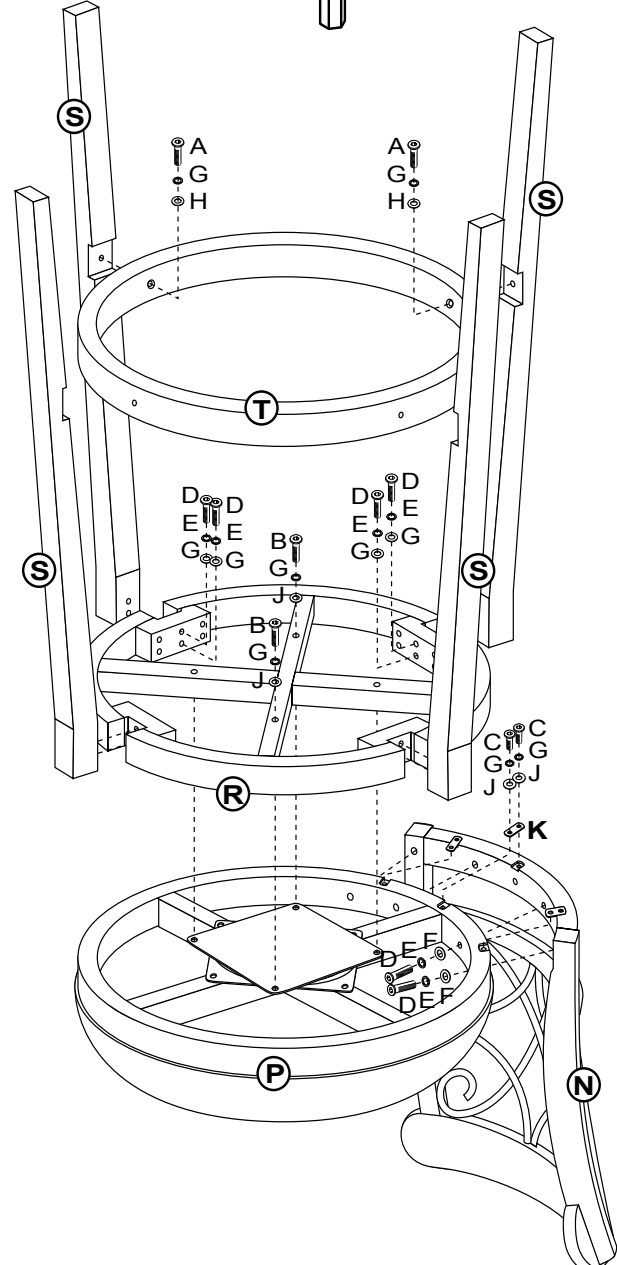

TOC20120620

**CARE & MAINTENANCE:** The touch of a soft cloth is all the maintenance the finish will ever need. Please do not use harsh or abrasive cleaners for polishing, as they may cause damage to the finish. Periodic checks are recommended to make sure that all bolts, screws and nuts are securely tightened.







Examine all packaging material for small parts that may have come loose during shipment. Periodic checks are recommended to insure that all components are in proper position, tight and free from damage. Keep this assembly instruction for future reference. Adult assembly is required. The product of Hillsdale Furniture, LLC is designed for residential use only. Customer Service Phone Number: 502-562-0000

**HARDWARE LIST**

- A (8) 5/16" x 2-3/8" Allen Bolts
- B (8) 5/16" Spring Washers
- C (8) 5/16" x 22x2mm Flat Washers
- D (1) 4mm Allen Wrench

**PIECES LIST**

- E (1) Table Top
- F (4) Legs
- G (1) Extension

PART	QTY	HARDWARE	PART	QTY	HARDWARE
A	8		B	8	
C	8		D	1	

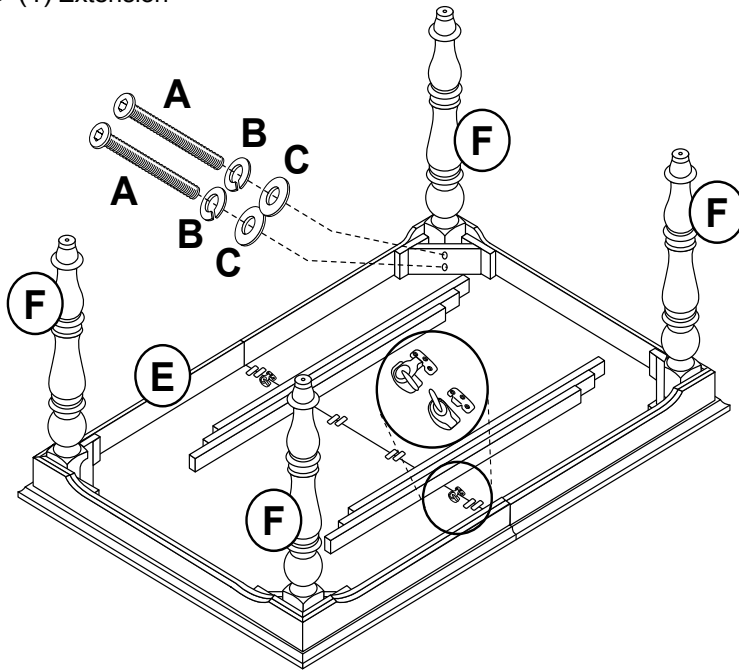

**STEP 1**

Begin by turning the table upside down on a clean smooth surface.

**STEP 2**

Next attach the Legs (F) to the Table Top (E) by using 2 Allen Bolts (A), 2 Spring Washers (B) and 2 Flat Washers (C) per leg.

**STEP 3**

To use the Extension (G), make sure the latches underneath are in the unlocked position and pull the two sides of the table apart. Next slide the Extension (G) into place and push the ends of the table back together and then make sure to put the latches into the locked position. The assembly is now complete.

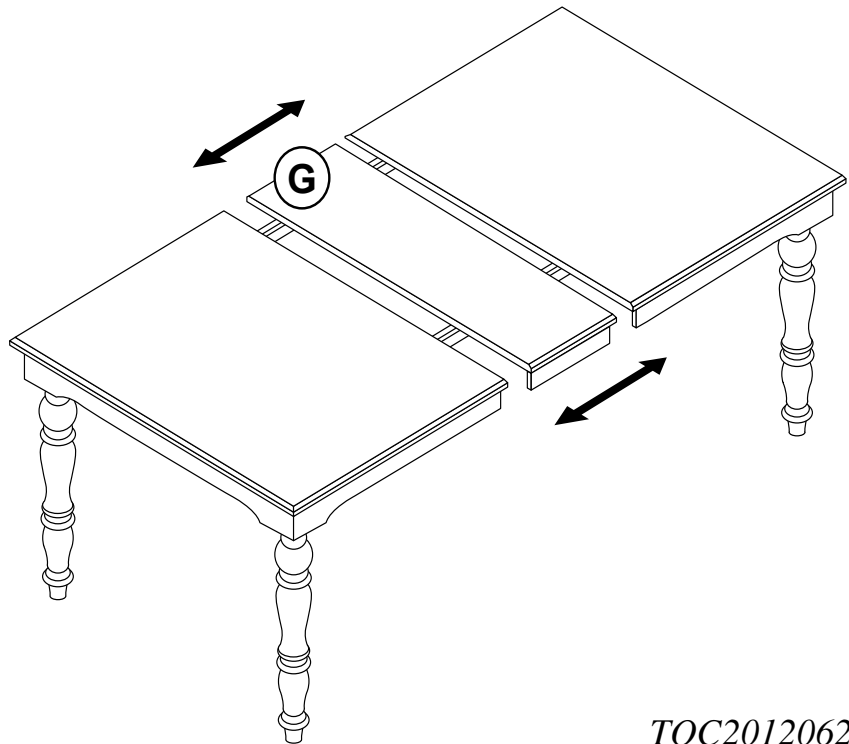

TOC20120620

**CARE & MAINTENANCE:** The touch of a soft cloth is all the maintenance the finish will ever need. Please do not use harsh or abrasive cleaners for polishing, as they may cause damage to the finish. Periodic checks are recommended to make sure that all bolts, screws and nuts are securely tightened.